

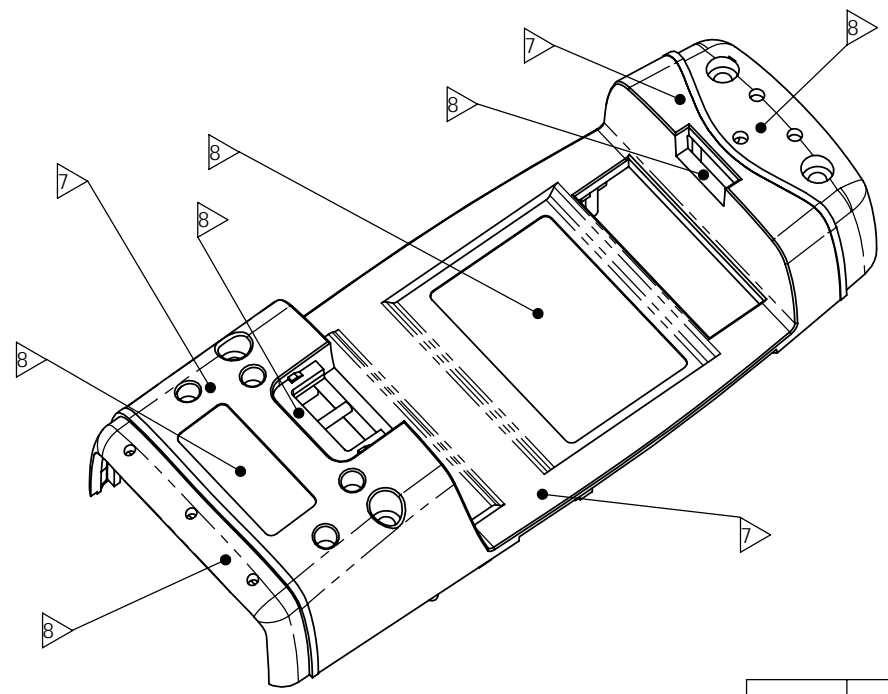

THE INFORMATION CONTAINED IN THIS DRAWING IS THE SOLE PROPERTY OF VISIONARY PRODUCTS, INC. ANY REPRODUCTION IN PART OR WHOLE WITHOUT THE WRITTEN PERMISSION OF VISIONARY PRODUCTS, INC. IS PROHIBITED. ALL RIGHTS RESERVED 1999, 2000, 2001, 2002

NOTES

1. MATERIAL: PC ABS. MUST BE APPROVED BY CUSTOMER.
2. FINISH: MT-11020.
3. COLOR: PANTONE COOL GREY 11C.
4. VOLUME: 15,499.04 CUBIC MILLIMETERS.
5. PART SHALL BE BUILT ACCORDING TO COMPUTER GENERATED SOLID FILES. DIMENSIONS IN PARENTHESIS ARE FOR REFERENCE ONLY. ALL OTHER DIMENSIONS ARE FOR QUALITY CONTROL TOLERANCES.
6. GATING DURING MOLDING SHALL BE ON THE CENTERLINE AND A NON-COSMETIC SURFACE.
7. COSMETIC TEXTURED SURFACES.
8. NON-TEXTURED SURFACES.
9. PART TO BE ROHS COMPLIANT.

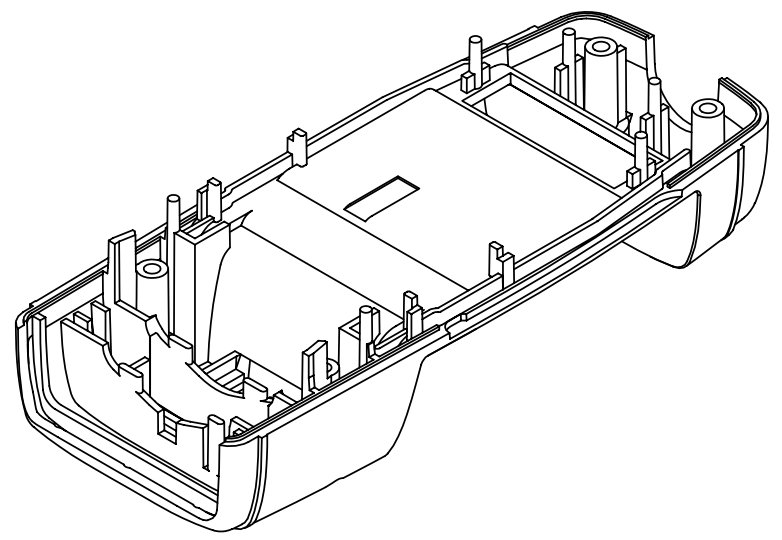

UNLESS OTHERWISE SPECIFIED DIMENSIONS ARE IN MILLIMETERS		APPROVALS	DATE
TOLERANCES ARE:		DRAWN M WENZEL	3-4-03
FRACTIONS DECIMALS ANGLES		CHECKED	
.X ± 0.5 X ± 0.5		COG ENG	
.XX ± 0.10 X ± 0.5		PROJECT MNGR	
.XXX ± 0.050 X.X ± 0.1			
MATERIAL			
SEE NOTE 1			
FINISH			
SEE NOTE 2		OA	
DO NOT SCALE DRAWING		RELEASED	

 VISIONARY PRODUCTS INC.		<h2 style="text-align: center;">CASE LOWER</h2>	
SCALE 1:1		SHEET 1 OF 3	

V001434	FLIPPER
APPLICATION	

THE INFORMATION CONTAINED IN THIS DRAWING IS THE SOLE PROPERTY OF VISIONARY PRODUCTS, INC. ANY REPRODUCTION IN PART OR WHOLE WITHOUT THE WRITTEN PERMISSION OF VISIONARY PRODUCTS, INC. IS PROHIBITED. ALL RIGHTS RESERVED 1999, 2000, 2001, 2002

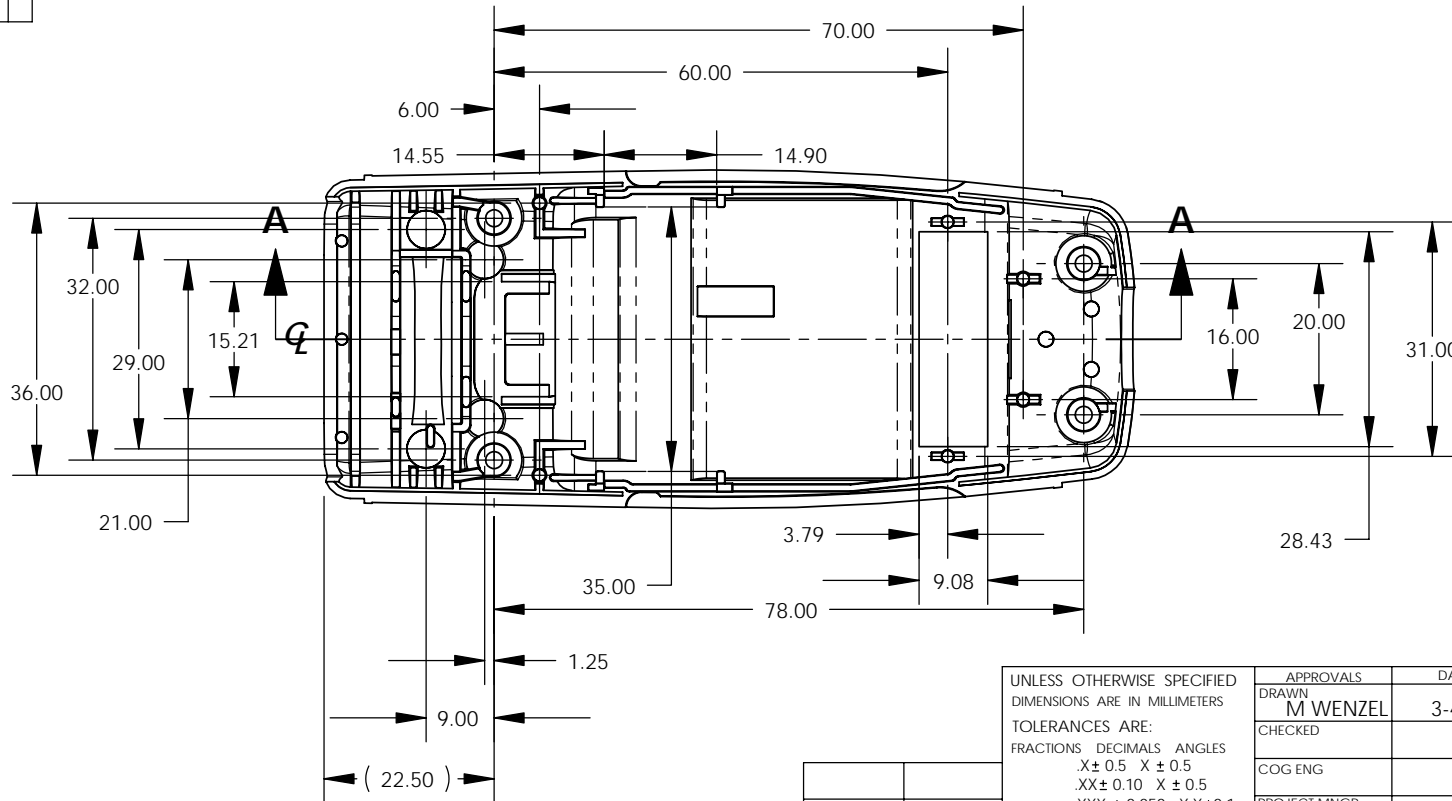
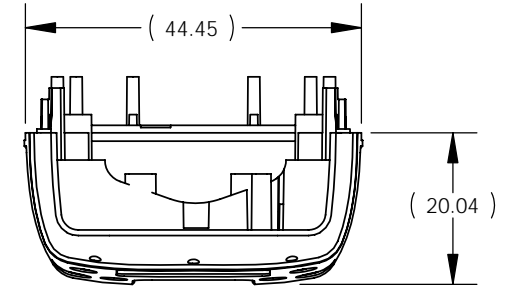
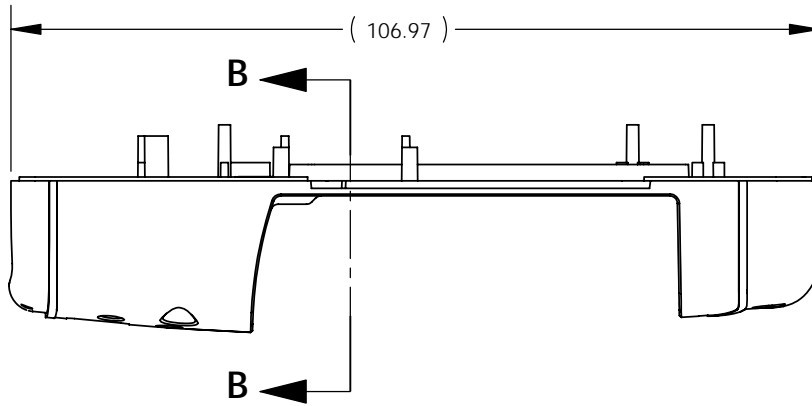

UNLESS OTHERWISE SPECIFIED
DIMENSIONS ARE IN MILLIMETERS
TOLERANCES ARE:
FRACTIONS DECIMALS ANGLES
.X ± 0.5 X ± 0.5
.XX ± 0.10 X ± 0.5
.XXX ± 0.050 X.X ± 0.1

APPROVALS	DATE
DRAWN M WENZEL	3-4-03
CHECKED	
COG ENG	
PROJECT MNGR	
OA	
RELEASED	

		VISIONARY PRODUCTS INC.	
CASE LOWER			
SIZE A	DWG. NO. V001202	REV. 08	
SCALE 1:1		SHEET 2 OF 3	

V001434	FLIPPER
APPLICATION	

DO NOT SCALE DRAWING

THE INFORMATION CONTAINED IN THIS DRAWING IS THE SOLE PROPERTY OF VISIONARY PRODUCTS, INC. ANY REPRODUCTION IN PART OR WHOLE WITHOUT THE WRITTEN PERMISSION OF VISIONARY PRODUCTS, INC. IS PROHIBITED. ALL RIGHTS RESERVED 1999, 2000, 2001, 2002

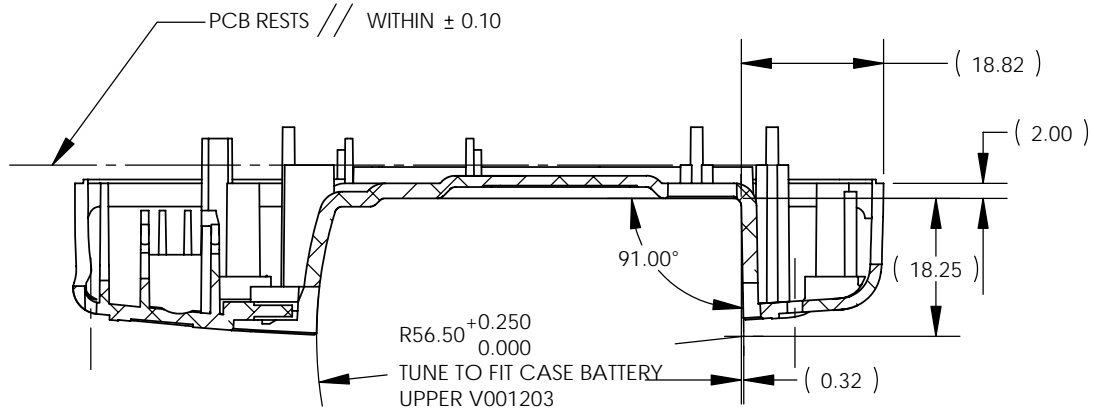

SECTION A-A

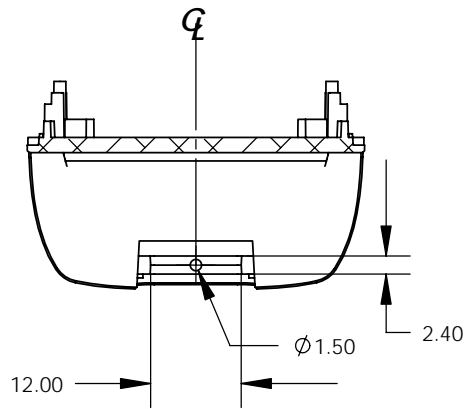

SECTION B-B

UNLESS OTHERWISE SPECIFIED DIMENSIONS ARE IN MILLIMETERS TOLERANCES ARE: FRACTIONS DECIMALS ANGLES .X ± 0.5 X ± 0.5 .XX ± 0.10 X ± 0.5 .XXX ± 0.050 X.X ± 0.1		APPROVALS	DATE
		DRAWN M WENZEL	3-4-03
		CHECKED	
		COG ENG	
MATERIAL		PROJECT MNGR	
FINISH		QA	
V001434	FLIPPER	RELEASED	

 VISIONARY PRODUCTS INC.		CASE LOWER	
SCALE 1:1		SHEET 3 OF 3	

V001434	FLIPPER
APPLICATION	

DO NOT SCALE DRAWING